

Datasheet for Synchronous-Permanent-Magnet-Motor INNOMOTICS



Motor type : 1SV5095L INNOMOTICS GP - 90 L - IM B3 - 6p - operation with frequency converter

Client order no.	Item-No.	Offer no.
Order no.	Consignment no.	Project

Remarks

Safe Area

Electrical data

U [V]	Δ / Y [-]	f [Hz]	P [kW]	P [hp]	I [A]	n [1/min]	M [Nm]	η [%]	$\cos\phi$ [-]	$L_d^{3)}$ [mH]	$L_q^{3)}$ [mH]	bEMF [V]	IE-CL [-]
380	Y	150	3	-/-	5.3	3000	9.5	91.1	0.95	14.3	41.5	339	IE5
IM B3 / IM 1001		FS 90 L		11 kg		IP55		IEC, DIN, ISO, VDE, EN			n_{max} 4500 1/min		IEC/EN TS 60034-30-2

Environmental conditions : -20 °C - +40 °C / 1000 m

These values are calculated. The final rating plate data will be calculated when the order is placed
The efficiency values and efficiency class according to EUP directive are valid for standard power ratings under standard conditions.

Mechanical data

Moment of inertia	0.00226 kg m ²	Insulation	155(F) to 130(B)
Bearing DE NDE	6205-2ZC3 6004-2ZC3	Duty type	S9
Bearing lifetime		Direction of rotation	bidirectional
L_{10mh} F_{Rad} min according catalogue 3000 1/min	40000 h	Frame material	aluminum
Regreasing device	Without	Net weight of the motor	11 kg
Grease nipple	Without	Motor weight incl. options	11 kg
Type of bearing	Floating bearings	Coating (paint finish)	Standard paint finish C2
Condensate drainage holes	Without	Color, paint shade	RAL7030
External earthing terminal	Without	Motor protection	(B) 3 PTC thermistors - for tripping (standard) (2 terminals)
Vibration severity grade	A	Method of cooling	IC411 - self-ventilated surface-cooled

Terminal box

Terminal box position	top	Main cable gland	1 plug
Material of terminal box	Aluminium	Cable diameter from ... to ...	-/- mm - -/- mm
Type of terminal box	TB1E00	Cable diameter from ... to ...	-/-
Contact screw thread	6xM4	Auxiliary cable entry	1 x M16 x 1.5
Max. cross-sectional area	4.0 mm ²	Auxiliary cable gland	1 plug
Main cable entry	1 x M25 x 1.5	Auxiliary cable diameter from ... to ...	-/- mm - -/- mm

L_d : D-inductance when the rotor is positioned on the d-axis. bEMF: The back electromotive force refers to the open-circuit RMS voltage (line-to-line) induced in the stator winding by the movement of the permanent magnets on the rotor. This value is given at 3000 1/min. 1) L_{10mh} according to DIN ISO 281 10/2010
 L_q : Q-inductance when the rotor is positioned on the q-axis. 2) at rated power / at full load
Note: Values are given for rated point currents. 3) Both values are used for motor control to optimize efficient operation.

Transmittal, reproduction, dissemination and/or editing of this document as well as utilization of its contents and communication thereof to others without express authorization are prohibited. Offenders will be held liable for payment of damages. All rights created by patent grant or registration of a utility model or design patent are reserved.

Responsible department IN LV	Technical reference	Created by IPC	Approved by Created automatically	Technical data are subject to change! There may be discrepancies between calculated and rating plate values.	Link documents
INNOMOTICS	Document type Technical data sheet	Document status Released			
	Document title 1FZ1005-OEL52-1AB4	Document number TDS-251217-144658			
Restricted © Innomotics 2025	Revision AA	Creation date 2025-12-17 14:46	Language en		Page 1/2

Datasheet for Synchronous-Permanent-Magnet-Motor INNOMOTICS



Motor type : 1SV5095L

INNOMOTICS GP - 90 L - IM B3 - 6p - operation with frequency converter

General data

Torque-Speed-Curves

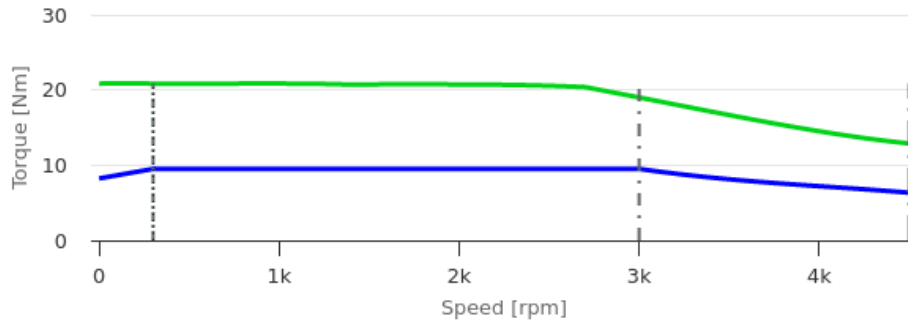

- Torque
- Torque Max
- - - n Min (Note: constant torque in range: $n_{Min} < n < n_{Nom}$)
- · - nNom
- nMax
- The displayed curve represents the motor characteristic; its behavior and controllability are directly dependent on the selected type of drive, which significantly influences the dynamics, accuracy, and stability of motor control, especially in the speed range from 0 to n_{Min}

Power-Speed-Curves

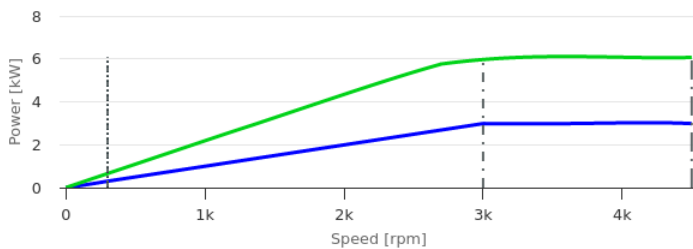

- Power
- Power Max
- - - n Min (Note: constant torque in range: $n_{Min} < n < n_{Nom}$)
- · - nNom
- nMax
- The displayed curve represents the motor characteristic; its behavior and controllability are directly dependent on the selected type of drive, which significantly influences the dynamics, accuracy, and stability of motor control, especially in the speed range from 0 to n_{Min}

Current-Speed-Curves

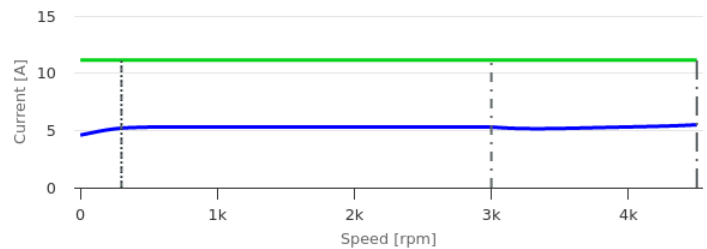

- Current
- Current Max
- - - n Min (Note: constant torque in range: $n_{Min} < n < n_{Nom}$)
- · - nNom
- nMax
- The displayed curve represents the motor characteristic; its behavior and controllability are directly dependent on the selected type of drive, which significantly influences the dynamics, accuracy, and stability of motor control, especially in the speed range from 0 to n_{Min}

L_d : D-inductance when the rotor is positioned on the d-axis.
 L_q : Q-inductance when the rotor is positioned on the q-axis.
 Note: Values are given for rated point currents.

bEMF: The back electromotive force refers to the open-circuit RMS voltage (line-to-line) induced in the stator winding by the movement of the permanent magnets on the rotor. This value is given at 3000 1/min.

1) L_{d0min} according to DIN ISO 281 10/2010
 2) at rated power / at full load
 3) Both values are used for motor control to optimize efficient operation.

Transmittal, reproduction, dissemination and/or editing of this document as well as utilization of its contents and communication thereof to others without express authorization are prohibited. Offenders will be held liable for payment of damages. All rights created by patent grant or registration of a utility model or design patent are reserved.

Responsible department IN LV	Technical reference	Created by IPC	Approved by Created automatically	Technical data are subject to change! There may be discrepancies between calculated and rating plate values.	Link documents
INNOMOTICS	Document type Technical data sheet	Document status Released			
	Document title 1FZ1005-OEL52-1AB4	Document number TDS-251217-144658			
Restricted © Innomotics 2025		Revision AA	Creation date 2025-12-17 14:46		

刀模圖樣所有權。業經註冊。特此公告。
 Transmittal, reproduction, dissemination and/or editing of this document as well as utilization of its contents and communication thereof to others without express authorization are prohibited. Offenders will be held liable for payment or damages. All rights created by patent grant or registration of a utility model or design patent are reserved.
 Weitergabe sowie Vervielfältigung, Verbreitung und/oder Bearbeitung dieses Dokumentes, Verwertung und Mitteilung seines Inhaltes sind verboten, soweit nicht ausdrücklich gestattet. Zuwiderhandlungen verpflichten zu Schadensersatz. Alle Rechte für den Fall der Patenterteilung, Gebrauchsmuster- oder Geschmacksmusterertragung vorbehalten.
 Confiado como secreto de empresa. Nos reservamos todos los derechos.
 Confia à titre de secret d'entreprise. Tous droits réservés.
 Comunicado como secreto empresarial. Reservados todos os direitos.
 Доверен в качестве производственного секрета.
 Все права сохраняются за нами.
 Certified as secret of company. All rights reserved.

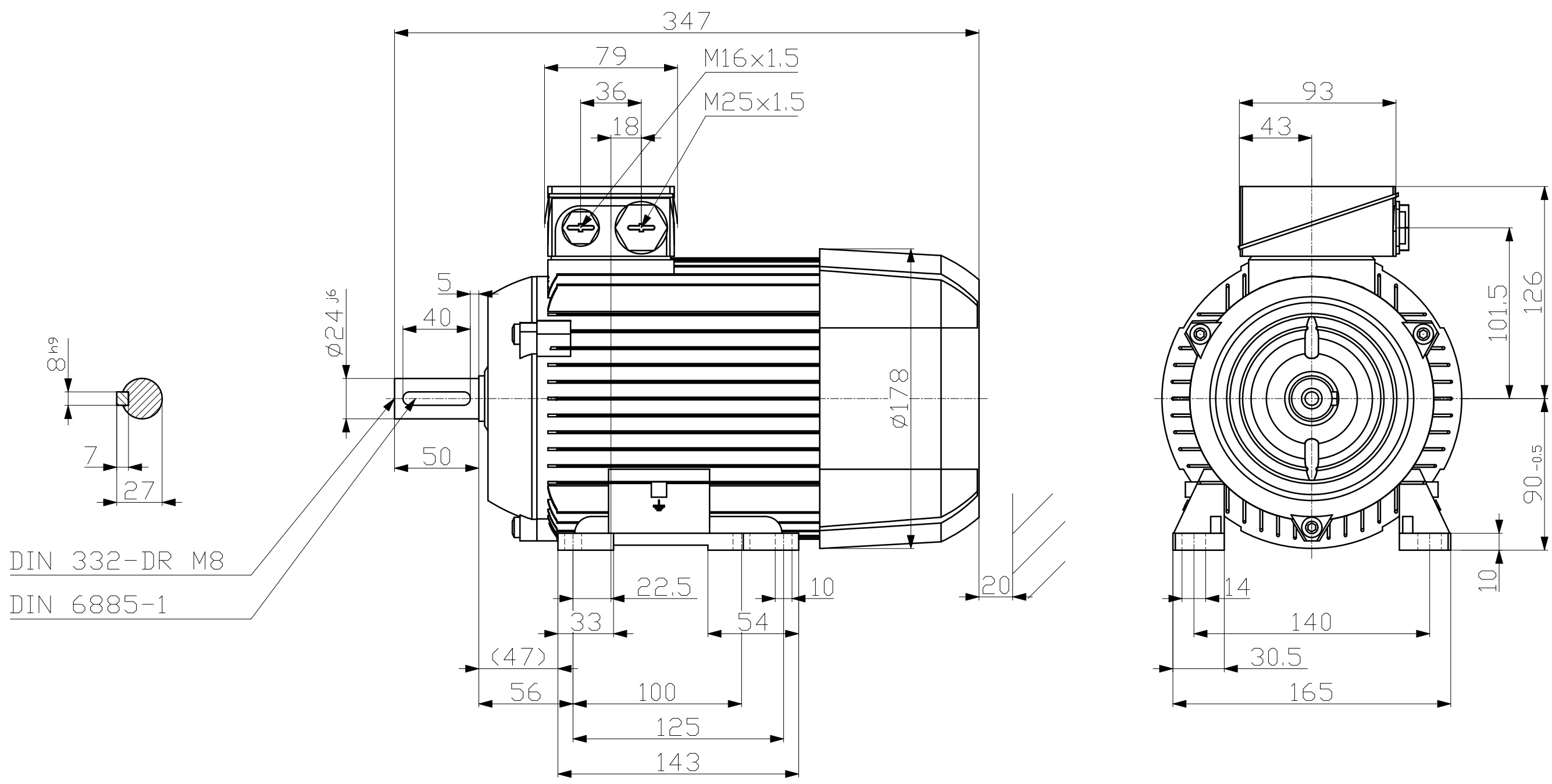

Technische Änderungen vorbehalten!
 Technical data are subject to change!

Tolerance	Surface	Material	Weight	Scale
1FZ1005-0EL52-1AB4	Author	Dimensional drawing		
	Creator 17/12/2025 IPC	Maßzeichnung		
	Approval Created automatically			
	Department IN LVM			
	Change Order	MLFB	Doc Type	
INNOMOTICS	Doc State Released	Item No	Paper Size A3	
	Revision AA Index RS	Doc No	1st Language en	
			2nd Language de	
©Innomotics 2025	Project No	Ref No	Sheet 1 of 1	