

CONFIGURATION OVERVIEW / MP708869/L1.R1

# Product code 3GBA182420-ADN

## M2BAX 180MLB 4, 22 kW, 4 poles

### GENERAL

MEPS	EU-MEPS	Altitude	1000 m.a.s.l.
MEPS scope	Inside	Ambient min / max	-20 °C / 40 °C
Motor design	BASIC	Ex atmosphere	No
Legal marking	CE	Customs tariff number	85015230

### MAIN CHARACTERISTICS

Motor type	M2BAX 180MLB 4
Product code	3GBA182420-ADN
ID code	
Shaft height	180 mm
Power	22 kW
Rated voltage $U_N$	400 V $\pm$ 5 % (IEC 60034-1)
Rated frequency $f_N$	50 Hz $\pm$ 2 % (IEC 60034-1)
Number of poles	4
Frame material	Cast Iron
Insulation class	F
Temperature class	-
Mounting	IM1001 IMB3

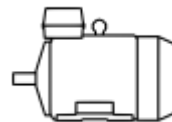

Enclosure protection class	IC411
Cooling	IP55
Weight	205 kg

**OPERATING POINTS**

Power [kW]	Voltage [V]	Connec-tion	Frequency [Hz]	Effic. Class	Efficiency [%]	Nominal Cur-rent [A]	Is/In	Duty	Speed [rpm]	T Rise
22	690	Y	50	IE4	94.5	23.7	9.2	S1	1479	B
22	400	D	50	IE4	94.5	41	9.2	S1	1479	B
22	660	Y	50	IE4	94.5	24	8.5	S1	1476	B
22	380	D	50	IE4	94.5	41.6	8.5	S1	1476	B

**VARIANT CODES**

No variant codes selected.

**MECHANICAL**

Direction of rotation	CW or CCW
Vibration	A
Paint colour	MUNSELL 8B 4.5/3.25
Paint system	C3 - Medium
Bearing, Drive end	Ball Bearing --
Bearing, Non-drive end	Ball Bearing --
Lubrication style	Greased for life
Main terminal box position	D-End top
Main terminal box turnable	4 x 90 degr
Main terminal cable entry	(2xM40+1xM16)x1.5
Fan material	Glass-fiber reinforced polypropylene
Fan cover material	Steel
Sound pressure level	65 LpdBA

**ACCESSORIES**

No accessories selected.

**MONITORING**

Winding PTC, PTC 1 per phase 150 degr. C  
 Vibration sensing, No SPM nipples

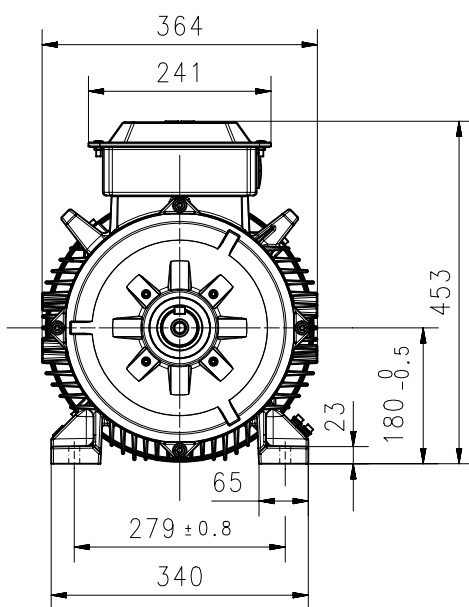
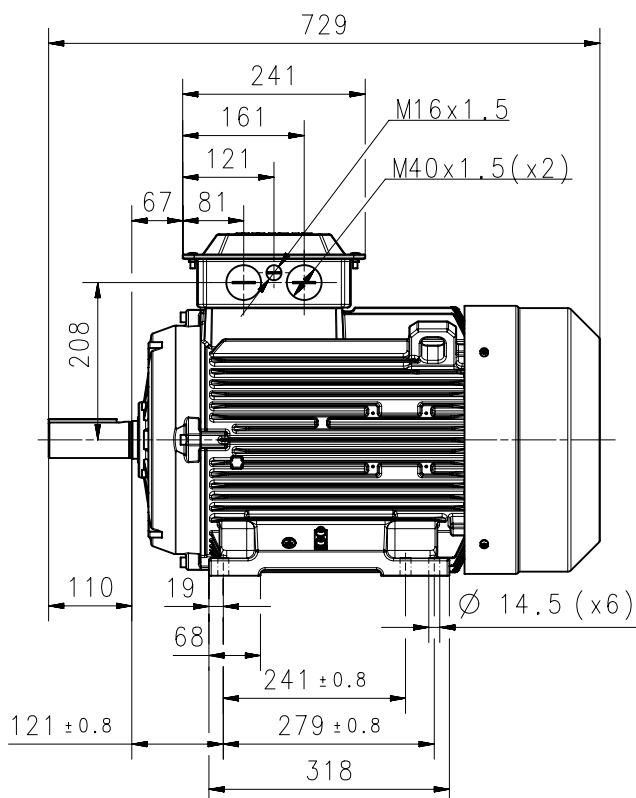
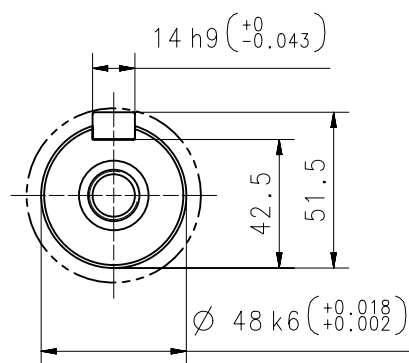
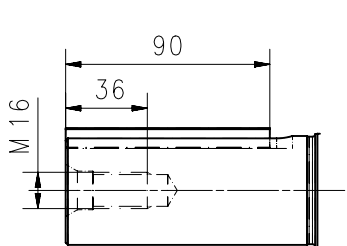

Additional information:

<b>Dimension Print</b>	Motor type: IE4M2BAX 180ML_2-6; B3, B6, B7, B8, V5, V6	Document No: 3GZC500018-274 A
------------------------	---	----------------------------------

Description: STANDARD SQUIRREL CAGE MOTOR

Unit: IEC LV Motors Date: 6-Dec-2021	Issued by: Gong, Alice-WenDan Approved by: Wang, Serena-Shinan	Replaces: Replaced by:
---	---	---------------------------

	Customer Reference:	
---	---------------------	---