

CONFIGURATION OVERVIEW / MP710303/L1.R1

Product code 3GBP311410-ADR

M3BP 315MLA 2, 160 kW, 2 poles

GENERAL

MEPS	EU-MEPS	Altitude	1000 m.a.s.l.
MEPS scope	Inside	Ambient min / max	-20 °C / 40 °C
Motor design	BASIC	Ex atmosphere	No
Legal marking	CE	Customs tariff number	85015381

MAIN CHARACTERISTICS

Motor type	M3BP 315MLA 2
Product code	3GBP311410-ADR
ID code	315C160P2EE5
Shaft height	315 mm
Power	160 kW
Rated voltage U_N	400 V \pm 5 % (IEC 60034-1)
Rated frequency f_N	50 Hz \pm 2 % (IEC 60034-1)
Number of poles	2
Frame material	Cast Iron
Insulation class	F
Temperature class	-
Mounting	IM1001 IMB3

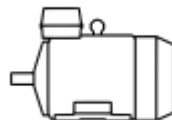

Enclosure protection class	IC411
Cooling	IP55
Weight	1190 kg

OPERATING POINTS

Power [kW]	Voltage [V]	Connec-tion	Frequency [Hz]	Effic. Class	Efficiency [%]	Nominal Cur-rent [A]	Is/In	Duty	Speed [rpm]	T Rise
160	690	Y	50	IE5	97	154	7.3	S1	2983	B
160	400	D	50	IE5	97	266	7.3	S1	2983	B
160	415	D	50	IE5	97	258	7.7	S1	2984	B
160	460	D	60	IE5	96.6	231	8.3	S1	3585	B
160	660	Y	50	IE5	97	160	6.6	S1	2981	B
160	380	D	50	IE5	97	279	6.6	S1	2981	B

VARIANT CODES

No variant codes selected.

MECHANICAL

Direction of rotation	-
Vibration	A
Paint colour	MUNSELL 8B 4.5/3.25
Paint system	C3 - Medium
Bearing, Drive end	Ball Bearing – 6316/C3
Bearing, Non-drive end	Ball Bearing – 6316/C3
Lubrication style	Regreasable
Main terminal box position	D-End top
Main terminal box turnable	4 x 90 degr
Main terminal cable entry	2xM63x1.5
Fan material	Glass-fiber reinforced polypropylene
Fan cover material	Steel
Sound pressure level	77 LpdBA

ACCESSORIES

No accessories selected.

MONITORING

Winding PTC, PTC 1 per phase 150 degr. C
 Vibration sensing, Standard SPM Nipples

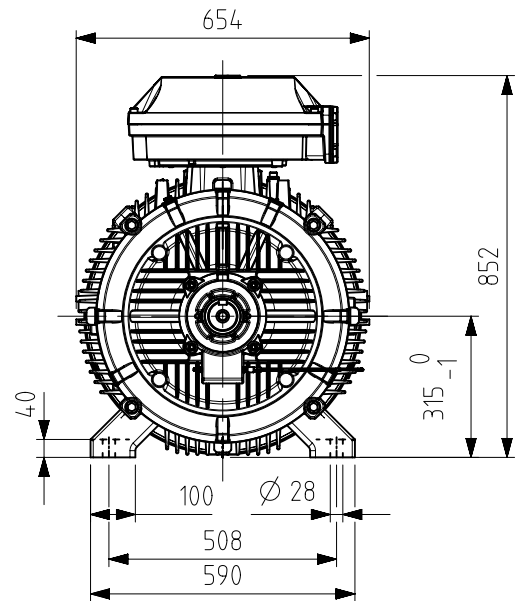
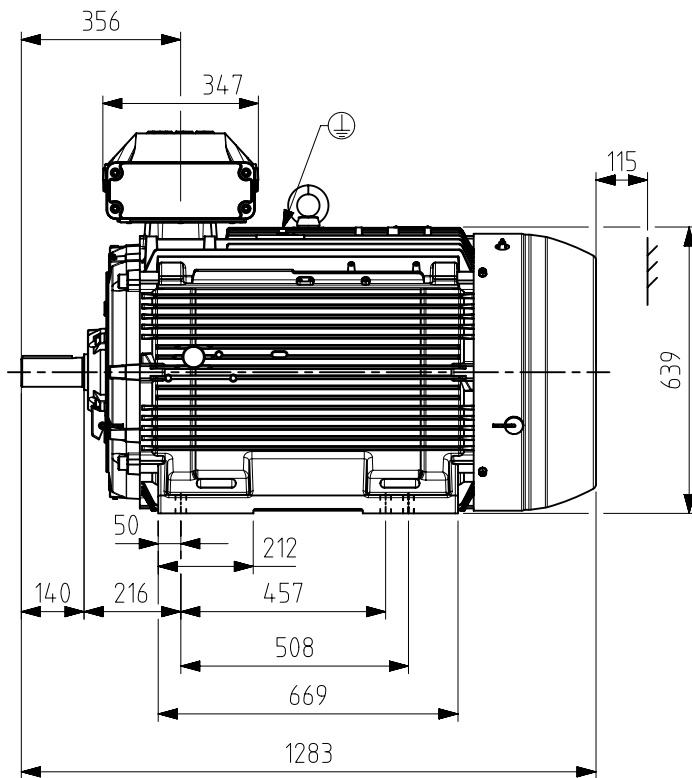
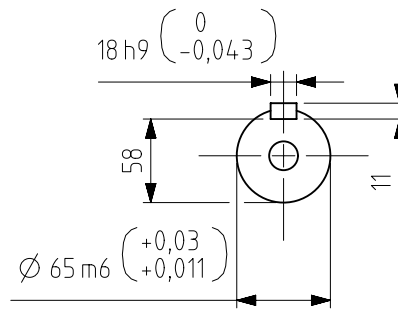
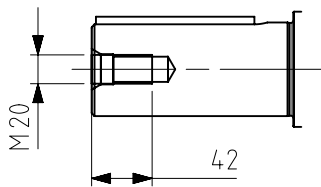

Additional information:

Dimension Print	M3BP315 (G/K/L/M) ML_2; B3, V5, V6, B6, B7, B8	Document No: 3GZF500031-3359 C
	M3GP315 ML_2; B3, V6, B6, B7, B8	

Description: STANDARD SQUIRREL CAGE MOTOR WITH TERMINAL BOX 370

Unit: IEC LV Motors Date: 21-Dec-2022	Issued by: Latvala, Tommi Approved by: Härämämaa, Arttu	Replaces: Replaced by:
--	--	---------------------------



Customer Reference:

