

Motordatenblatt *motor datasheet*

Motortyp *motor type*
 Artikelnummer *item no.*

15AA 80 M2-4, 3~, 4p
 52401000751



Elektrische Daten Netzbetrieb

electrical data DOL

U [V]	D/Y [-]	f [Hz]	P [kW] [hp]	I [A]	n [1/min]	M [Nm]	Nom. Eff [%] @... load			cos phi @... load			Ia/In [-]	Ma/Mn [-]	Mk/Mn [-]	IE Cl. [-]
							[4/4]	[3/4]	[2/4]	[4/4]	[3/4]	[2/4]				
230	D	50	0,75	3,04	1430	5,01	82,5	82,9	81,5	0,75			6,6	2,2	2,3	IE3
400	Y	50	0,75	1,75	1430	5,01	82,5	82,9	81,5	0,75			6,6	2,2	2,3	IE3
460	Y	60	0,86	1,68	1716	4,79	85,5			0,75						IE3
B3			80 M		12,5 kg		IP55			IEC, DIN, ISO, VDE, EN						

Umgebungsbedingungen *environmental conditions*

Umgebungstemperatur <i>ambient temperature</i>	-20	bis <i>to</i>	40	°C
Höhe über Meeresspiegel <i>altitude above sea level</i>	1000			m

Mechanische Daten *mechanical data*

Gehäusematerial <i>frame material</i>	Aluminium <i>aluminum</i>			
Kondenswasserlöcher <i>drain holes</i>	nein <i>no</i>			
Trägheitsmoment <i>moment on inertia</i>	0,00269825			kgm ²
Äussere Erdungsklemme <i>outer earthing connector</i>	nein <i>no</i>			
Anstrich <i>paint work</i>	RAL7030	Standardanstrich <i>standard paintwork</i>		
Wellenende Abmessungen <i>shaft dimension</i>	Ø 19	x	40	mm

Anschlusskasten *terminal box*

Anschlusskastenmaterial <i>terminal box material</i>	Aluminium <i>aluminum</i>			
Anschlusskasten Lage <i>terminal box position</i>	oben <i>top</i>			
Gewindebolzen <i>terminal bolt thread</i>	M4			
max. Leiterquerschnitt <i>max. cable cross-sectional area</i>	2,5			mm ²
Gewinde für Kabelverschr. <i>thread for cable gland</i>	2 x M20 x 1,5			
Betriebskondensator <i>operating capacitor</i>				µF
Anlaufkondensator <i>starting capacitor</i>				µF

Hinweise

- PTC sofern im Auftrag spezifiziert / PTC if specified in order

Motorschutz *protection*

Zündschutzart <i>type of protection</i>	-
Motorschutz <i>protection</i>	ohne Motorschutz <i>without winding protection</i>

Allgemeine Daten *general data*

Schalldruckpegel 50/60 Hz (LpFA) <i>noise 50/60 Hz (LpFA)</i>	56	dB		dB
Kühlart <i>method of cooling</i>	IC411			
Vibrationsklasse <i>vibration class</i>	A			
Wuchtung <i>balancing</i>	Halbkeil <i>half key</i>			
Isolation <i>insulation</i>	155(F)			
Betriebsart <i>duty type</i>	S1			
Drehrichtung <i>direction of rotation</i>	bidirektional <i>bidirectional</i>			

Lagerung *bearing*

Art der Lagerung <i>locating bearing</i>	schwimmende Lagerung <i>no located bearing</i>			
Lager A-/ B-Seite <i>bearing DE / NDE</i>	6204 2Z C3		6204 2Z C3	
Nachschmierung <i>regreasing</i>	Nein <i>no</i>		Nein <i>no</i>	
Intervall <i>intervall</i>	-	Std. <i>h</i>	-	Std. <i>h</i>
Fettmenge <i>quantity of grease</i>	-	g	-	g
Fettsorte <i>grease type</i>	-			

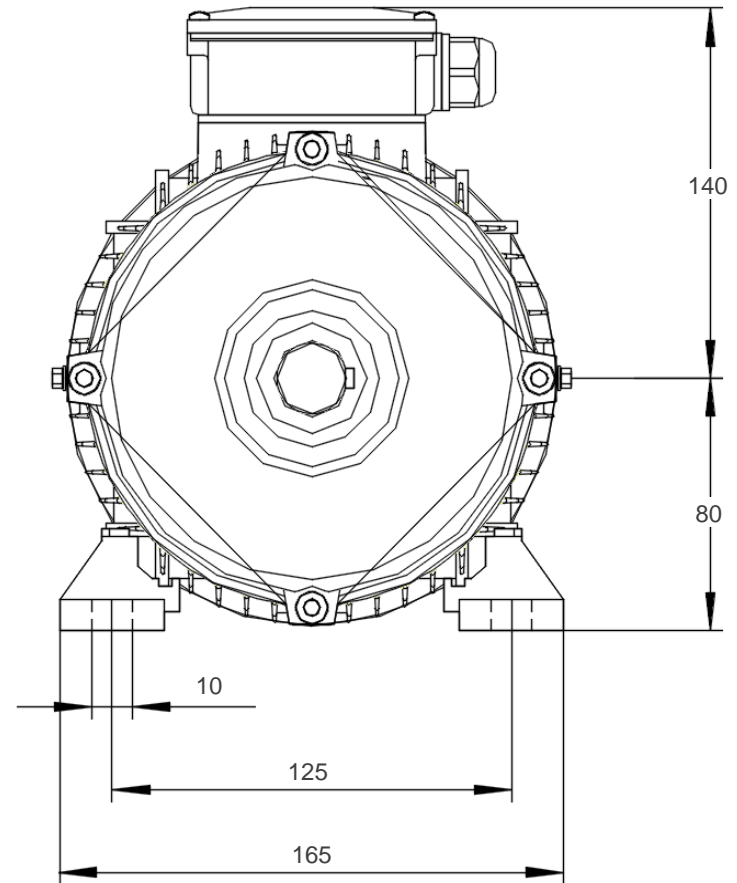
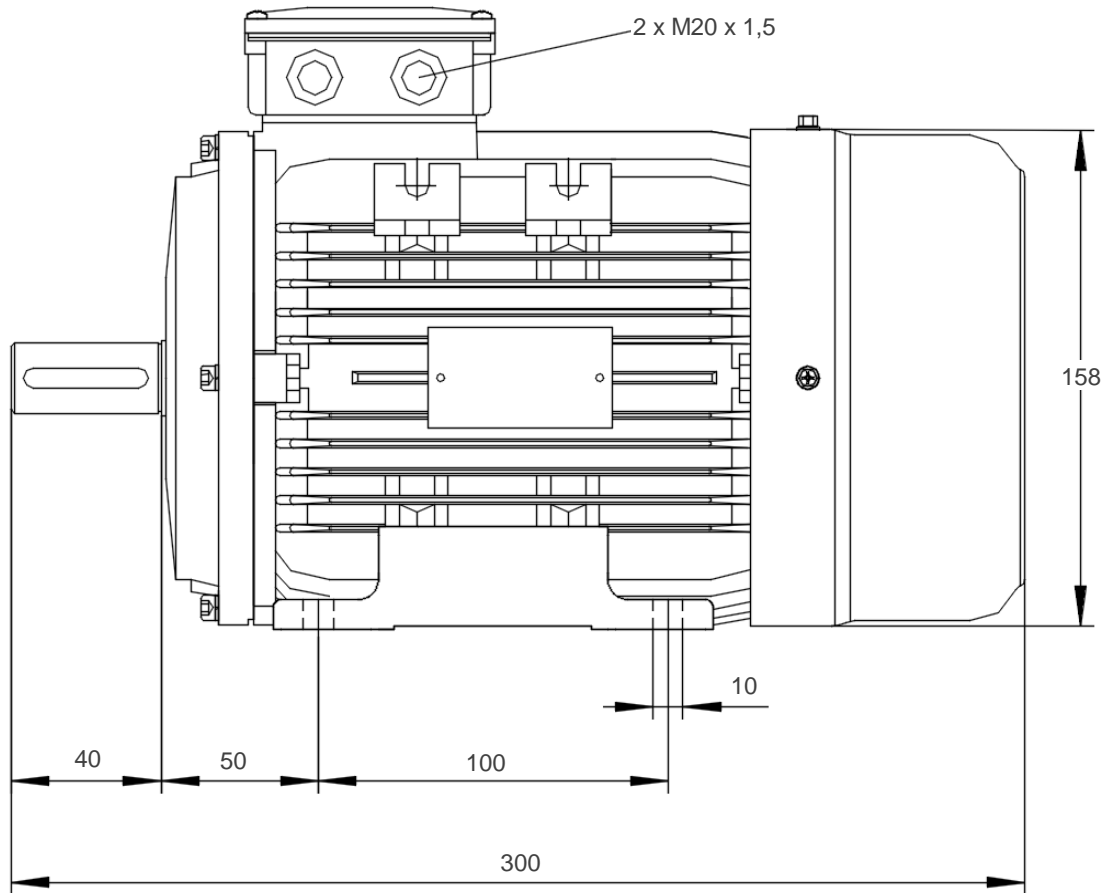

Welle A-Seite
shaft DE

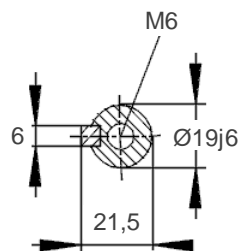

Änderungen und Irrtümer vorbehalten / Subject to change without prior notice!

Datum / Date 26.02.2024

Version 5.00.0062



15AA80 M2-4 - B3